

Return Voltage Measurements – Diagnostic Interpretations on the Basis of the Dielectric Time Constants

Rainer PATSCH, Dieter KAMENKA*, Johannes MENZEL
Institute of Materials & Diagnostics in Electrical Engineering
University of Siegen, Germany
*sebaKMT, Radeburg, Germany

Abstract: Return Voltage Measurements of paper-oil insulations such as medium voltage cables have proven to be a reliable method to determine the actual state of degradation and/or the humidity of the insulation.

As a first step the interpretation of the measurements can be done on the basis of the p-factor. This parameter is sensitive on the dielectric properties and especially the **humidity of the solid part of the insulation**, whereby aged or humid cables show a higher p-factor.

The calculation of the **dielectric time constants** τ_1 and τ_2 of the two insulating materials oil and cellulose is unique for the Return Voltage Method and hence exceeds the information extractable from other diagnostic methods.

Key words: return voltage, paper-oil insulation, boundary polarization, ageing, Maxwell Model, dielectric time constants

BASICS OF THE RETURN VOLTAGE METHOD

The principle is known since many years [1-3], the readings are reproducible and reliable, at least with regard to the collection of the data, but unfortunately not always with regard to all methods of interpretation. Return Voltage Measurements are less sensitive to disturbances by external noise, a situation that is favourable for measurements in the field. The extractable information is comparable to that derived from other dielectric methods like e.g. the measurement of polarization and depolarization currents [4, 5].

The experimental procedure is the following:

Application of a **dc** voltage U_p for the time t_p , formation of a short circuit for the time t_a , and measurement of the voltage that builds up between the external electrodes after the release of the short circuit. Commonly used parameters of the return voltage curves are the peak voltage U_m , the time t_m of the voltage peak and the initial incline s of the curve. In many cases a linear dependence of the return voltage curve on the height of the poling voltage exists, but in some cases a sub linear dependence may indicate some ageing. The **p-factor** defined as

$$p = \frac{U_m}{s t_m} \quad (1)$$

does not depend on the height of the poling voltage U_p and is also independent of the geometric parameters of the cable. Ageing and degradation processes increase the p-factor.

INTERPRETATION OF EXPERIMENTAL RESULTS

The analysis of return voltage curves or of polarization and depolarisation currents over time is often done by a numerical fit on the basis of equivalent circuits consisting of three or more **RC series-elements** with different time constants in parallel (**Fig. 1 b**) shows only one RC-element). This equivalent circuit is physically adequate for the description of **atomic polarization processes** in insulating materials, namely for molecules with different polarizabilities. For other processes such as e.g. the built-up of space charges or boundary polarization processes such an equivalent circuit is just a tool for a **formal mathematical fit** without any correspondence to physical parameters.

DIELECTRIC BEHAVIOUR OF A MULTILAYER INSULATION

The insulation of classic power equipment such as **oil filled power transformers** or **cables with paper-oil-insulation** consists of different insulating materials with different dielectric properties (ϵ_r and σ) and thus – in addition to molecular processes in the short time range – shows the phenomenon of **boundary polarization**, i.e. the accumulation of charge carriers at the boundaries between the different dielectrics.

If a **dc** voltage is applied to the external electrodes of such a system, starting with a **capacitive voltage distribution**, a continuous change into a **resistive voltage distribution** occurs. Electric charges move within the

different dielectrics and in part accumulate at the **interfaces**, where they generate local electric fields that are necessary to fulfil the **continuity equation** for the current density and the necessary correlations between the electric fields at both sides of the interface.

After removal of the poling voltage, during the **short circuit** an instantaneous release of the charges at the external electrodes takes place and the **charges accumulated at the inner boundaries move** within the dielectric materials, thus producing a **discharge current**. After the release of the short circuit this current generates a **voltage difference between the two external electrodes**, that first increases, passes a maximum and decreases again, thus producing the **Return Voltage Curve**. In so far no single molecular polarization or depolarization processes are responsible for the experimentally found behaviour of compound insulations during Return Voltage Measurements.

MAXWELL MODEL

For **boundary polarization** – and this is the relevant process in power equipment with paper-oil insulation – another equivalent circuit, the **Maxwell Model** with two **RC parallel-circuits in series**, is more appropriate, because it closely **reproduces the physical reality** [6]. **Fig. 1 a)** shows the basic equivalent circuit. This circuit is in good correspondence with a physical model discussed in the literature for power equipment with paper-oil insulation [7].

The equivalent circuit in accordance to the Maxwell Model can be transformed into the commonly used equivalent circuit with RC series elements that is commonly used to describe molecular polarization processes. If the measured specimen consists of two parts connected in parallel, as e.g. a cable length consisting of two parts with different properties two Maxwell circuits

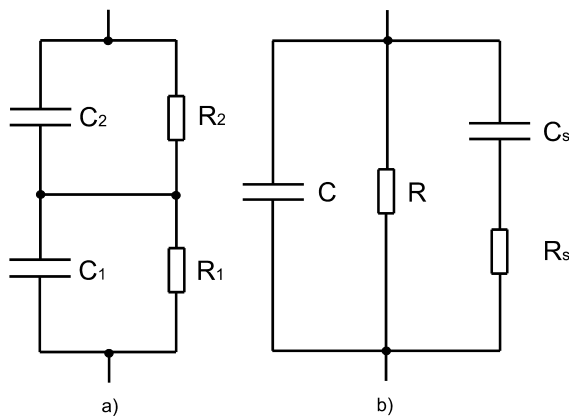

Fig. 1: Equivalent circuits to describe return voltage curves, a) physically relevant model, b) formal equivalent circuit

in parallel must be used for the description. In the formal equivalent circuit a second RC series element is necessary.

Both equivalent circuits shown in Fig. 1 are able to describe the return voltage curves. They can be transformed into each other [8].

$$C = \frac{C_1 C_2}{C_1 + C_2}, \quad R = R_1 + R_2 \quad (3)$$

$$C_s = \frac{(R_2 C_2 - R_1 C_1)^2}{(R_1 + R_2)^2 (C_1 + C_2)} \quad (4)$$

$$R_s = \frac{R_1 R_2 (R_1 + R_2) (C_1 + C_2)^2}{(R_2 C_2 - R_1 C_1)^2} \quad (5)$$

$$\tau_s = \frac{R_1 R_2 (C_1 + C_2)}{R_1 + R_2} \quad (6)$$

The two equivalent circuits can be used for basic discussions e.g. with regard to the influence of the measuring resistance R_m or the influence of a parallel capacitance C_m . The time constant τ_s of the RC series element equals the time constant τ of the Maxwell equivalent circuit during polarization or under short circuit conditions.

According to the Maxwell Model the shape of the return voltage curve $U_r(t)$ can be calculated analytically and (neglecting the influence of R_m at the moment) is given by

$$U_r(t) = U_s \left(e^{-t/\tau_2} - e^{-t/\tau_1} \right) \quad (7)$$

U_s is the voltage over C_1 and C_2 immediately after the release of the short circuit and is influenced by the polarization voltage U_p , the elements R_1 , R_2 , C_1 and C_2 of the equivalent circuit the time of polarization t_p and the time of short circuit t_d .

$$U_s = \frac{\lambda - 1}{1 + \lambda + \frac{R_2}{R_1} + \frac{C_2}{C_1}} U_p \left(1 - e^{-t_p/\tau} \right) e^{-t_d/\tau}$$

$$\text{with } \tau = \frac{\tau_2 R_1 + \tau_1 R_2}{R_1 + R_2} \quad (8)$$

The time constants $\tau_2 = R_2 C_2$ and $\tau_1 = R_1 C_1$ of the two **RC parallel elements** in the equivalent circuit correspond to the physical **dielectric time constants** $\tau_i = \rho_i \epsilon_i$ of the two dielectrics **cellulose** ($i=2$) and **oil** ($i=1$) [9] and R_m is the resistance of the measuring circuit. The correspondence of the elements in the equivalent circuit and the physical properties of the real dielectric in the measured object is obvious. The inner resistance R_p of

the insulation or any other parasitic resistances at splices or terminations behave in the same way.

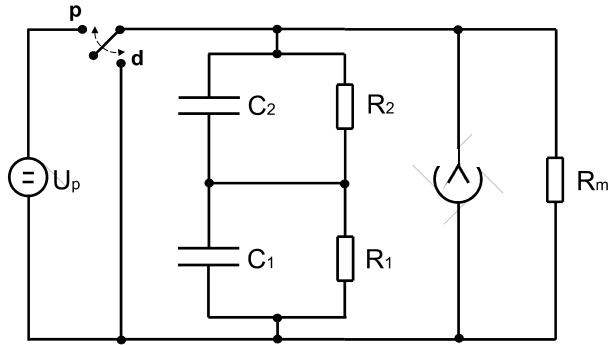

Fig. 2: Equivalent circuit of a paper-oil-dielectric with $\tau_2 = R_2 C_2$ and $\tau_1 = R_1 C_1$ and basic measuring circuit

PARAMETERS USED FOR RVM EVALUATION

The three basic parameters used for the evaluation of Return Voltage Measurements can be calculated analytically. The diagnostic parameters s and U_m contain U_s as a factor and are consequently influenced by the geometric dimensions of the object under test. The time t_m of the voltage maximum depends on the ratio $\lambda = \tau_2 / \tau_1$ and the time constant τ_1 only.

$$U_m = U_s \left(\lambda^{1/(1-\lambda)} - \lambda^{\lambda/(1-\lambda)} \right) \quad (9)$$

$$s = \frac{U_s}{\tau_1} \left(\frac{\lambda-1}{\lambda} \right) \quad (10)$$

$$t_m = \tau_1 \left(\frac{\lambda}{\lambda-1} \right) \ln \lambda \quad (11)$$

The ratio U_m/s does not depend on U_s but only on τ_1 and the ratio $\lambda = \tau_2 / \tau_1$

$$\frac{U_m}{s} = \tau_1 \frac{\lambda}{\lambda-1} \left(\lambda^{1/(1-\lambda)} - \lambda^{\lambda/(1-\lambda)} \right) \quad (12)$$

In addition to the use of the standard plots of U_r over t as a first documentation of the measurement result, a more effective characterization of the results of return voltage measurements can be made by the analysis of the dependence between the two parameters U_m/s and t_m . Both parameters contain τ_1 and depend only on the ratio $\lambda = \tau_2 / \tau_1$. The ratio between the two parameters can be taken as a new parameter λ [10].

The **p-factor** defined as

$$p = \frac{U_m}{s t_m} = \frac{\lambda^{1/(1-\lambda)} - \lambda^{\lambda/(1-\lambda)}}{\ln \lambda} \quad (13)$$

eliminates not only the factor U_s but also τ_1 , since s is inversely and t_m is directly proportional to τ_1 . p only depends on the ratio $\lambda = \tau_2 / \tau_1$ of the two time constants instead of R_1 , C_1 , R_2 and C_2 separately. Hence the **p-factor** is not only **independent of the geometric dimensions of the two dielectrics** but also independent of all parameter changes that influence τ_1 and τ_2 in the same way. This holds - at least in first approximation - e.g. for the influence of the temperature of the measured object. This may be important if measurements performed in different seasons of the year are compared [11]. In addition the **p-factor** is also independent of the height of the polarization voltage, because both, s and U_m are proportional to U_p . On the other hand, if p changes with the polarization voltage this is an indication of field dependent conductivities in the dielectrics, possibly as a consequence of ageing processes.

EVALUATION OF τ_1 AND τ_2

A very interesting and unique possibility of the interpretation of the experimental results on the basis of the **Maxwell Model** is the possibility to use the dependence of U_m/s on t_m to calculate the **time constants** τ_1 and τ_2 of the two RC elements of the equivalent circuit in **Fig. 2**. These **time constants** are characteristic for the two dielectrics **paper** and **oil** in the cable, and - important for application of the method in the field - they do not depend on the actual geometry of the specimen i.e. neither the cable length nor the cross section of the conductor or the insulation thickness are of importance.

For an insulating material the dielectric time constant τ is proportional to $\rho \epsilon$, the product of the specific resistance ρ and the relative permittivity ϵ . The time constant is sensitive to changes of ρ and ϵ , whereby for cellulose materials the specific resistance ρ is very sensitive to the content of water. In the case of paper-oil-insulations one of the main parameters in the ageing process is the **water content of the paper** that on one hand **accelerates ageing** and on the other hand **appears as a degradation product**. Hence the ageing process significantly influences the corresponding dielectric time constant τ_2 .

By use of the eqns. (13) and (11) it is possible to calculate the time constants τ_2 and τ_1 directly from the experimental parameters U_m , t_m and s . The **time constants** are per definition independent of the specimen geometry and thus characterize directly the **dielectric properties** of the two insulating materials **paper** and **oil**.

INFLUENCE OF THE MEASURING RESISTOR

For short lengths of cables in very good condition a complication may arise. This is the case if the input resistance R_m of the measuring system is of the same size

as the leakage resistance of the measured object, or - in terms of the equivalent circuit - comes into the region of values of the resistors \mathbf{R}_1 and \mathbf{R}_2 . In this case the influence of the additional resistor \mathbf{R}_m cannot be neglected. The analysis shows that in this case the type of the return voltage curve indicated in eqn. (1) remains, but the time constants τ_1 and τ_2 are changed. Instead of τ_1 and τ_2 , effective time constants τ_1' and τ_2' must be used and also different elements in the equivalent circuit.

The resistor \mathbf{R}_m influences τ_1 and τ_2 but not U_s . The quantitative influence of this resistance can be calculated analytically. Eqns. (14) – (17) show the correlations.

$$U_R(t) = U_s \left(e^{-t/\tau_2'} - e^{-t/\tau_1'} \right) \quad (14)$$

$$\tau_2' = \left(\alpha - \sqrt{\alpha^2 - \beta} \right)^{-1} \quad (15)$$

$$\tau_1' = \left(\alpha + \sqrt{\alpha^2 - \beta} \right)^{-1}$$

$$\alpha = \frac{1}{2} \left[\frac{\tau_1(\mathbf{R}_2 + \mathbf{R}_m) + \tau_2(\mathbf{R}_1 + \mathbf{R}_m)}{\tau_1 \tau_2 \mathbf{R}_m} \right] \quad (16)$$

$$\beta = \frac{(\mathbf{R}_1 + \mathbf{R}_2 + \mathbf{R}_m)}{\tau_1 \tau_2 \mathbf{R}_m} \quad (17)$$

with $\tau_1 = \mathbf{R}_1 \mathbf{C}_1$ and $\tau_2 = \mathbf{R}_2 \mathbf{C}_2$

SITUATION IN REAL MEASUREMENTS

In dependence on the actual structure of the distribution network, different lengths of cable segments are to be measured and hence the capacitance \mathbf{C}_p and the resistance \mathbf{R}_p of the measured cable sections are different.

In principle the return voltage curve does not depend on the length of a measured cable, because every part of the cable contributes with a certain amount of current from the depolarization processes, whereby the current per length of the cable is constant. This current charges the cable and since the capacitance \mathbf{C}_p of the measured cable is also proportional to its length, no dependence of the return voltage curve on the length of the cable should occur.

The measurement resistor \mathbf{R}_m of the measurement system leads to a discharge of the cable capacitance \mathbf{C}_p and hence may influence the real return voltage curve. A characteristic parameter to describe this influence is the time constant $\tau_m = \mathbf{C}_p \mathbf{R}_m$ of the system. If this time constant is significantly higher than the time t_m at which the maximum of the return voltage occurs, the influence of \mathbf{R}_m can be neglected.

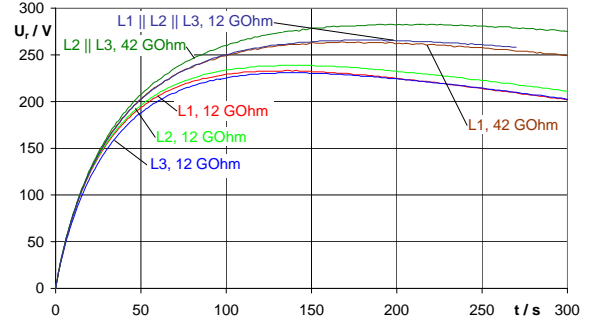

Fig. 3: Return voltage curves from measurements of the three cores L1, L2 and L3 of a 150 m long cable (GA9) with different measuring resistors

If the time constant $\tau_m = \mathbf{C}_p \mathbf{R}_m$ is in the same region or smaller than the time constants τ_1 and τ_2 in **Fig. 2** there is an influence of the measurement procedure on the experimentally found return voltage curve. It is obvious, that the shorter the cable is, the more pronounced the influence of \mathbf{R}_m may be. Hence the **p-factor** calculated from the return voltage curve may be higher as a consequence of the measurement resistor, thus indicating a higher degradation of the cable.

To evaluate the influence of the measurement resistor \mathbf{R}_m experiments were performed with cables of different lengths and with different measurement resistors. The results show that the explanation given is relevant.

In one set of experiments the three cores **L1**, **L2** and **L3** of a cable of **150 m** length were measured with measuring resistors of **12** and **42 GΩ**. In some measurements two or three cores of the cable were measured in parallel, thus forming specimens with different lengths. The results are shown in **Fig. 3**. The curves from the three cores are very similar. The measurement of core **L1** alone with **42 GΩ** generates nearly the same curve as the measurement of **L1 || L2 || L3** with **12 GΩ**, a result that verifies the influence of the time constant $\tau_m =$

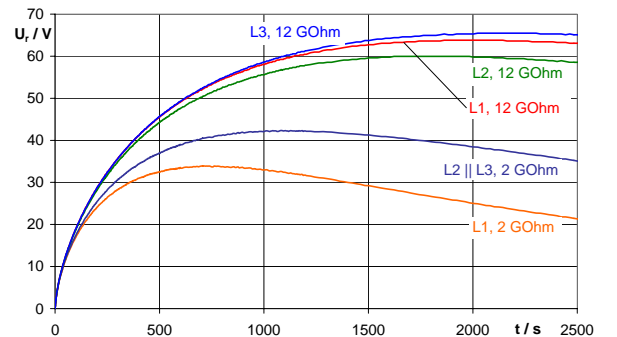

Fig. 4: Return voltage curves from measurements of the three cores L1, L2 and L3 of a 1300 m long cable (TOR) with different measuring resistors

$\mathbf{C}_p \mathbf{R}_m$. Cores **L2** and **L3** in parallel show a slightly

higher return voltage curve. In this case even with a measurement resistor of $42 \text{ G}\Omega$ a small dependence on the length of the measured object exists.

Another set of measurements was performed with a cable of 1300 m length. This cable was measured with resistors of 2 and $12 \text{ G}\Omega$. Also in this case single cores or two or three cores in parallel were measured. The results are shown in Fig. 4. The dependence found is similar as aforementioned.

For another cable with a length of 330 m (HEI) measurements were performed using measuring resistors of 12 and $62 \text{ G}\Omega$. Due to the influence of the measurement resistor, in the measurement with $12 \text{ G}\Omega$ a slightly higher p-factors were found.

The measurements with $62 \text{ G}\Omega$ showed no length dependence of the p-factors and the calculated dielectric time constants. The comparison of the measurements of L1, L1 || L2 and all three cores in parallel showed values that were to be expected with respect to the separate measurements of the three cores. Table 1 shows the p-factors and the dielectric time constants calculated from the aforementioned measurement data.

$12\text{G}\Omega$	L1	L2	L3
U_m / V	35.6	36.86	47.39
t_m / sec	312	331	325
$s / \text{V/sec}$	0.672	0.725	0.771
p	0.170	0.154	0.189
$\lg \tau_2 / \text{sec}$	4.24	4.50	4.01
$\lg \tau_1 / \text{sec}$	1.73	1.71	1.80

$62 \text{ G}\Omega$	L1	L2	L3
U_m / V	33.0	38.2	60.5
t_m / sec	329	405	405
$s / \text{V/sec}$	0.671	0.759	0.892
p	0.150	0.124	0.167
$\lg \tau_2 / \text{sec}$	4.56	5.19	4.38
$\lg \tau_1 / \text{sec}$	1.70	1.70	1.84

$62 \text{ G}\Omega$	L1 L2	L3	L1 L2 L3
U_m / V	36.8	57.6	41.4
t_m / sec	371	417	373
$s / \text{V/sec}$	0.701	0.908	0.717
p	0.142	0.152	0.155
$\lg \tau_2 / \text{sec}$	4.77	4.63	4.53
$\lg \tau_1 / \text{sec}$	1.72	1.81	1.77

Table 1: p-factors and dielectric constants for the measurements of cable HEI (3 cores of 330 m each) with different measuring resistors and for different circuits

The time constants τ_1 were about 50 s in all cases. For the measurements of one, two or three cores with $62 \text{ G}\Omega$ no length dependence was found. The measurements of parallel circuits showed dielectric time con-

stants compatible to the results of single measurements of the cores. Fig. 5 shows the calculated dielectric time constants τ_1 and τ_2 for the measurements of different parallel circuits of the three cores with $62 \text{ G}\Omega$.

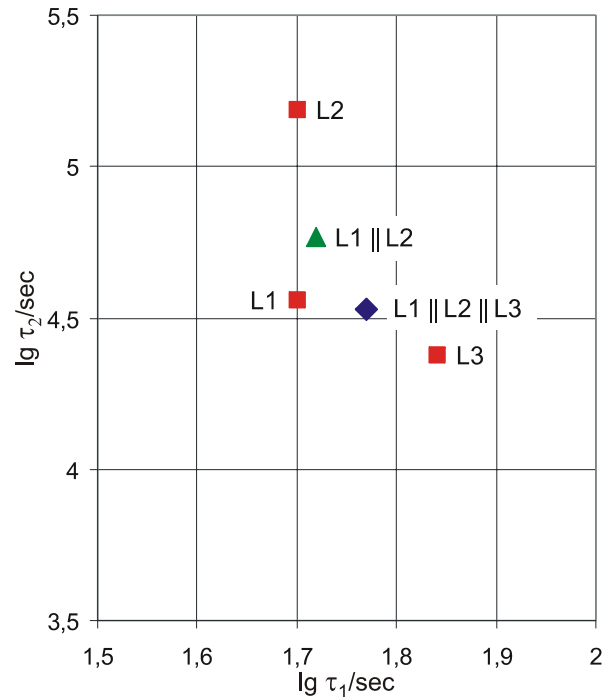

Fig. 5: Dielectric time constants τ_1 and τ_2 for the measurements with $62 \text{ G}\Omega$ (selection from Table 1).

Whether the measurement resistor R_m has an influence on the measured results depends on the 'quality' of the measured object. If the measurement resistor is significantly higher than the over all resistance R_p of the insulation of the measured cable (including all splices, terminations etc.) the return voltage curve is not significantly influenced.

In general shorter cable lengths tend to show higher p-factors and lower time constants τ_2 , but this is not always the case. Different cables of similar lengths often show different p-factors and different time constants τ_2 thus allowing a relative ranking.

Measurements of cables in one utility showed no influence of the cable lengths at all. In this case it showed up that the cables in general showed a high degree of degradation, so – even for low lengths of the cables – the inner resistances R_p of the cables were significantly smaller than the measuring resistor R_m .

FURTHER EXPERIENCE FROM THE FIELD

Similar to other diagnostic methods, return voltage measurements in different seasons of the year may show different results. **Fig. 6** and **Table 2** show results from three measurements within 14 months.

Jan/01	L1	L2	L3
U_m / V	171	192	167
t_m / sec	1178	1463	1052
$s / V/sec$	1.94	1.82	1.84
p	0.075	0.073	0.086
$lg \tau_2/sec$	7.74	8.03	7.01
$lg \tau_1/sec$	1.95	2.02	1.96

Aug/01	L1	L2	L3
U_m / V	387	449	343
t_m / sec	403	606	302
$s / V/sec$	8.96	8.82	9.04
p	0.107	0.084	0.126
$lg \tau_2/sec$	5.68	6.88	5.03
$lg \tau_1/sec$	1.64	1.71	1.58

Mar/02	L1	L2	L3
U_m / V	197	220	181
t_m / sec	1087	1283	937
$s / V/sec$	2.22	2.10	2.10
p	0.082	0.082	0.092
$lg \tau_2/sec$	7.27	7.36	6.69
$lg \tau_1/sec$	1.95	2.02	1.94

Table 2: p-factors and dielectric constants for different measurements of the three cores of cable DYR

Sep/99	L1	L2	L3
U_m / V	569	590	590
t_m / sec	165	165	171
$s / V/sec$	29.7	29.1	28.4
p	0.116	0.123	0.121
$lg \tau_2/sec$	5.02	4.83	4.89
$lg \tau_1/sec$	1.28	1.31	1.32

Mar/00	L1	L2	L3
U_m / V	306	273	370
t_m / sec	129	96	203
$s / V/sec$	10.7	10.7	11.5
p	0.222	0.266	0.159
$lg \tau_2/sec$	3.29	2.82	4.21
$lg \tau_1/sec$	1.49	1.47	1.51

Table 3: p-factors and dielectric constants for the measurements of the three cores of cable GER6 in different seasons of the year

Compared to the measurement in winter, as a consequence of the higher temperature of the soil around the cable, the measurement in summer resulted in lower

dielectric time constants for paper and oil. The second measurement in the cold season showed that no ageing had occurred, the dielectric time constants were the same as 14 months before.

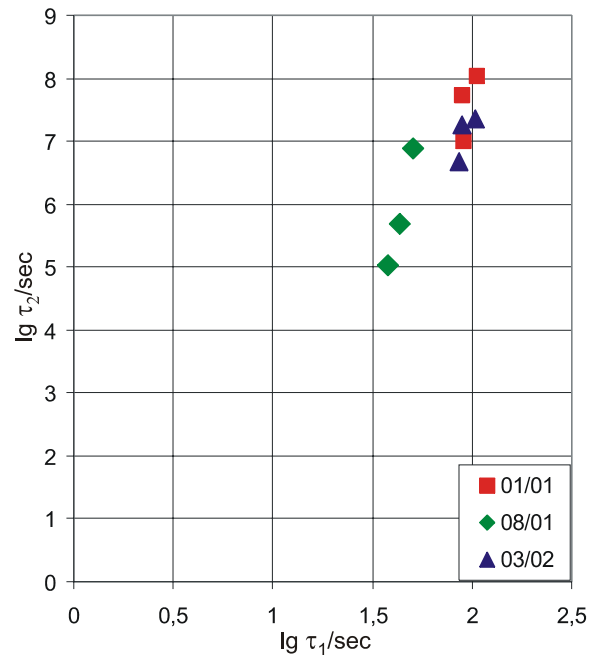

Fig. 6: Dielectric time constants for measurements of cable DYR in different seasons of the year (see table 2)

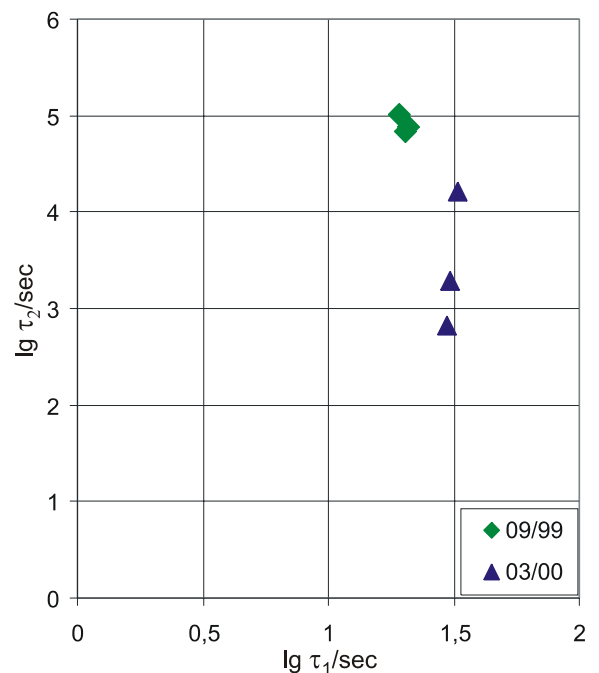

Fig. 7: Change of the dielectric time constants as a consequence of ageing during 6 months (see table 3)

The ageing processes in a cable in general lead to a decrease of the resistance of the cellulose. The same holds for an uptake of water in the cellulose, whereby water on one hand accelerates the degradation of the cellulose and on the other hand water also occurs as a degrada-

tion product. Thus ageing will result in a decrease of the time constant τ_2 of the cellulose. The time constant τ_1 of the oil will be influenced only to a less extent.

The described ageing processes have been found also in practice. **Fig. 7** shows the results of two measurements of a cable in different seasons of the year. In this case the first measurement was performed in summer. The measurement 6 months later expectedly showed higher time constants τ_1 of the oil. Interestingly the time constants τ_2 of the cellulose had decreased. The ageing of the cores during the time interval between the two measurements was different (see **Table 3**). The p-factors showed corresponding changes.

In a set of measurements in one utility the cables measured showed the general tendency that – for cables of lengths below a few hundred meters – the p-factors increased with decreasing lengths. But nevertheless even in this dataset, cables of nearly identical lengths showed significantly different p-factors, indicating different degradations.

Measurements of cables in another utility showed no influence of the cable lengths. For these cables with a higher degree of degradation the influence of the measuring resistor was not relevant even for lengths of about 100 m [12].

SUMMARY

In dependence on the actual condition of a cable examined with the Return Voltage Method the diagnostic result may be influenced by the actual length of the cable. The calculated **p-factor** of short cable lengths may be higher than representative for the degree of degradation, indicating a more severe degree of ageing. This influence can be overcome by the use of higher measuring resistors or by an appropriate correction of the measured data.

On the basis of the **Maxwell Model**, the appropriate concept for the description of the phenomena that occur in a paper-oil insulation, the return voltage curves can be used to calculate the dielectric time constants τ_1 and τ_2 of the two dielectrics paper and oil. Ageing and degradation of the insulation significantly reduces the **time constant τ_2 of the cellulose**.

REFERENCES

- [1] Németh, E.: Zerstörungsfreie Prüfung von Isolationen mit der Methode der Entlade- und Rückspannungen. **IWK'66**, Ilmenau, Germany, (1966), 87-91
- [2] Bogнар, A.; Kalocsai, L.; Csepes, G.; Németh, E.; Schmidt, J.: Diagnostic Tests of High Voltage Oil-Paper Insulating Systems (In Particular Transformer Insulation) using DC Dielectrometrics, **CIGRE'90**, Paris, France, (1990), 15/33-08
- [3] Németh, E.: Practical experiences of diagnostic testing of power cable lines by the voltage-response method. **IWK'95**, Ilmenau, Germany, (1995), 699-708
- [4] Zaengl, W. S.: Dielectric Spectroscopy in Time and Frequency Domain for HV Power Equipment, Part I: Theoretical Considerations. **IEEE EI-Mag.**, **19**, No. 5, (2003), 5-19
- [5] Zaengl, W. S.: Applications of Dielectric Spectroscopy in Time and Frequency Domain for HV Power Equipment. **IEEE EI-Mag.**, **19**, No. 6, (2003), 9-22
- [6] Patsch, R.; Berton, F.; Kouzmine, O.: The Influence of the Ambient Temperature on the Diagnostic Response of Paper-Oil Insulated Cables. **APTADM'01**, Wrocław, Poland, (2001), 34-37
- [7] Houhanessian, V. D.: Measurement and Analysis of Dielectric Response in Oil-Paper Insulation Systems. PhD-Thesis, ETH Zürich, Switzerland, (1998)
- [8] Alekseev, B. A.: A new method for detecting moisture in the insulation of transformer windings. **Elektrichestvo**, No. 2, (1959), 58-63
- [9] Patsch, R.; Kouzmine, O.: Diagnostic Parameters in Return Voltage Measurements of Oil-Paper Insulation Systems; **WSEAS Trans. on Circuits and Systems**, **9**, (2005), 1191-9
- [10] Patsch, R.; Kouzmine, O.: p-Factor, a Meaningful Parameter for the Evaluation of Return Voltage Measurements. **CEIDP'02**, Cancun, Mexico, (2002), 906-9
- [11] Patsch, R.; Kouzmine, O.: The Influence of Climatic Conditions on the Diagnostic Results of Return Voltage Measurements. **ISEI'02**, Boston, USA, (2002), 191-4
- [12] Patsch, R.; Kouzmine, O.: Return Voltage Measurements - a good Tool for the Diagnosis of Paper-Oil-Insulations. **IEEE PowerTech**, St. Petersburg, Russia, (2005), CD